

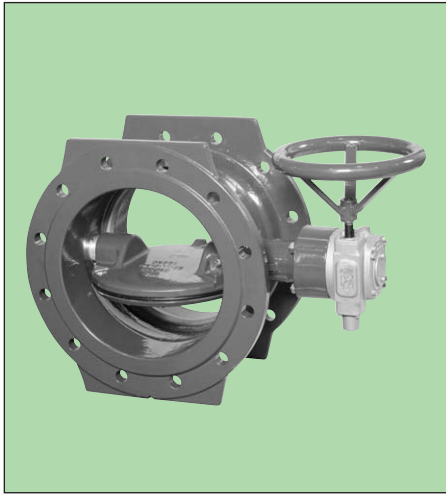

PN 6...40
DN 150...3000



Product Features

- To EN 593
- Disk double offset
- Disk with closed disk eyes
- Automatic soft sealing system
- Sealing ring can be replaced without dismantling the valve
- Body seat wear and corrosion resistant due to nickel welded overlay, micro finished
- With worm gear box with limit stops at the input shaft and position indicator
- Face to face to EN 558-1, series 14 (DIN 3202, F4)
- DVGW approved
- Final Inspection Tests acc. to EN 12266 (DIN 3230 part 4)

Materials

- Body and disk of ductile cast iron EN - JS 1030 (GGG-40)
- Valve shaft of stainless steel
- Sealing rings and O-rings of EPDM
- Shaft bearing bushes of bronze

Accessories

- T-key
- Dismantling joint
- Surface box, cast iron
- Surface box, plastic
- Surface box, plastic, adjustable
- Supporting plate, plastic
- Handwheel

DIN-DVGW approval

- DN 150...1200 PN 10, 16 approved

Corrosion Protection

- Body inside and outside, and disk epoxy coated, min. 250 microns

Field of Application

- Max. operating temperatures: 50 °C

Alternatives

- Pressure rate: PN 6 DN 900...3000 - PN 10 DN 200...3000
PN 16 DN 150...2500 - PN 25 DN 150...1200
PN 40 DN 150...1000 (max. differential pressure 32 bar)
- With electrical actuator
- With pneumatic or hydraulic actuator
- With brake and lift cylinder

For information about installation, commissioning, operating and maintenance we kindly refer to **KAT 234 200-B (1310-B)**.

Field of Use Water Final Inspection Tests in acc. with EN 12266 water

DN mm	PN bar	Max. differential pressure	Max. operating temperature °C	Test pressure in bar	
				body	seat
900...3000	6	10	50	9	7
200...3000	10	10	50	15	11
150...2500	16	16	50	24	18
150...1200	25	25	50	37.5	28
150...1000	40	32	50	60	35

Field of Use Gas Gas systems in acc. with DIN 30690 Final Inspection Tests in acc. with EN 12266 gas

DN mm	PN bar	Max. differential pressure bar	Max. operating temperature for gases ¹⁾ in acc. with DVGW-G-260 with air °C ²⁾	Test pressure in bar			
				body	with water in body	with air in body	seat
150...1200	10	10	50	0.5	15	11	0.5 and 11
150...1200	16	16	50	0,5	24	17,6	0,5 and 17,6

¹⁾ Gases with no more than 5 g/operational m³-benzyl content.

²⁾ Neutral gases, dry up to 90° C.

We reserve the right to make technical changes and use similar or higher-quality materials. Drawings are non-binding



Dimensions

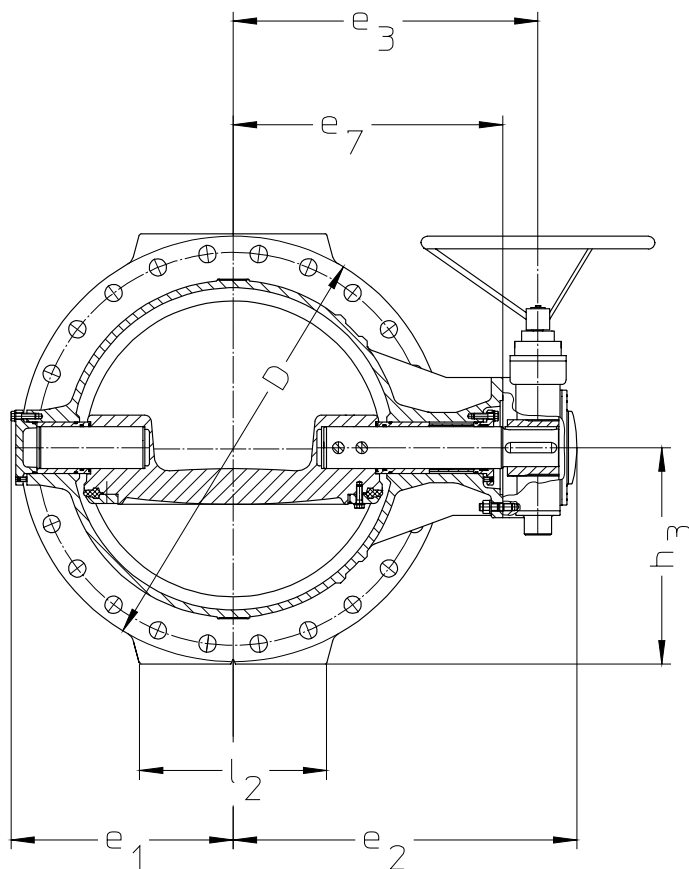
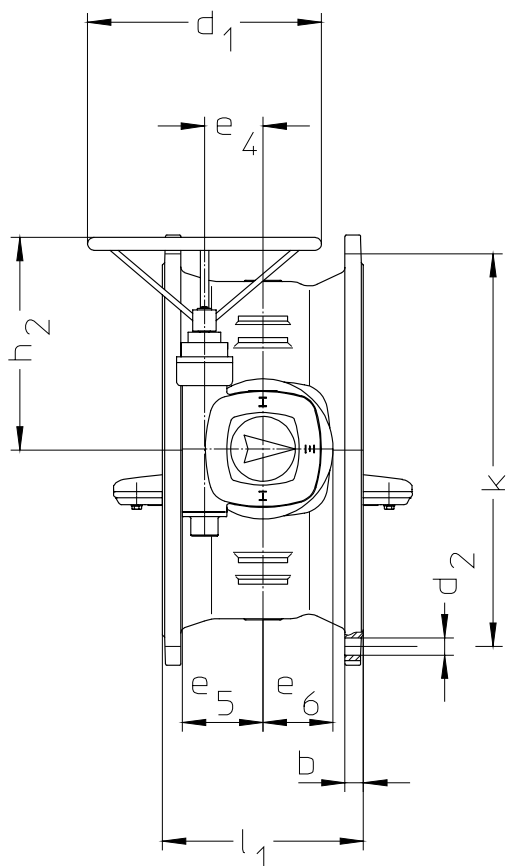

Design details

Shaft bearing

DN 150...1200

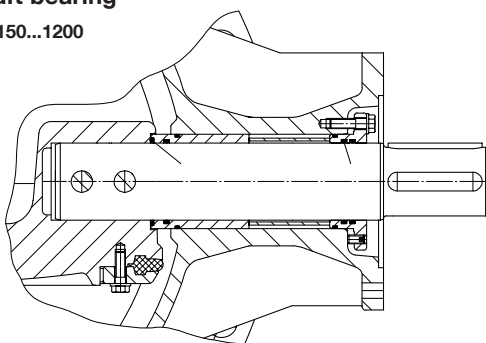

DN >1200

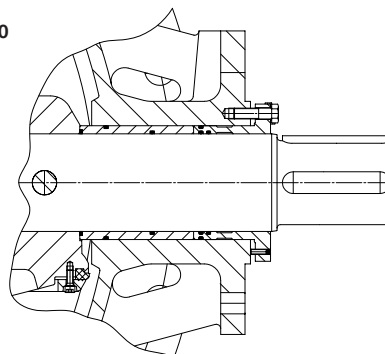

Body/Disk seal

DN 150...1200

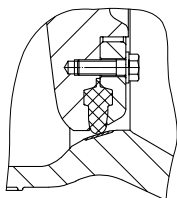

DN >1200

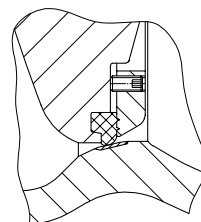



Dimensions / weights

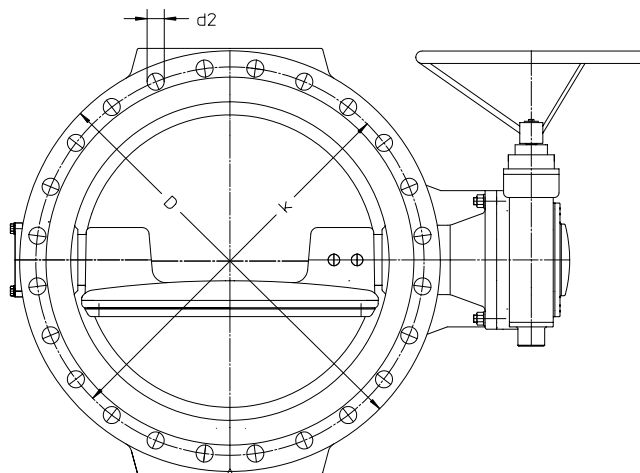

Dimensions in mm														
DN		150	200	250	300	350	400	450	500	600	700	800	900	1000
Face to face to EN 558-1 14	l_1	210	230	250	270	290	310	330	350	390	430	470	510	550
PN 6*...10	D	285	340	400	455	505	565	615	670	780	900	1020	1120	1245
	k	240	295	350	400	460	515	565	620	725	840	950	1050	1160
	Holes	8	8	12	12	16	16	20	20	20	24	24	28	28
	d_2	23	23	23	23	23	28	28	28	31	31	34	34	37
	b	19	20	22	24.5	24.5	24.5	26.5	26.5	30	32.5	35	37.5	40
PN 16	D	285	340	400	455	520	580	640	715	840	910	1025	1125	1255
	k	240	295	355	410	470	525	585	650	770	840	950	1050	1170
	Holes	8	12	12	12	16	16	20	20	20	24	24	28	28
	d_2	23	23	28	28	28	31	31	34	37	37	41	41	44
	b	19	20	22	24.5	26.5	28	31.5	31.5	36	39.5	43	46.5	50
PN 25	D	300	360	425	485	555	620	670	730	845	960	1085	1185	1320
	k	250	310	370	430	490	550	600	660	770	875	990	1090	1210
	Holes	8	12	12	16	16	16	20	20	20	24	24	28	28
	d_2	28	28	31	31	34	37	37	37	41	44	50	50	57
	b	20	22	24.5	27.5	30	32	34.5	36.5	42	46.5	51	59.5	60
PN 40	D	300	375	450	515	580	660	685	755	890	995	1140	1250	
	k	250	320	385	450	510	585	610	670	795	900	1030	1140	1250
	Holes	8	12	12	16	16	16	20	20	20	24	24	28	28
	d_2	28	31	34	34	37	41	41	44	50	48	56	56	56
	b	20	30	34	39.5	44	48	49	52	58	64	65	70	75

Dimensions in mm									
DN		1100	1200	1300	1400	1500	1600	1800	2000
Face to face to EN 558-1 14	l_1	590	630	670	710	750	790	870	950
PN 6*...10	D	1340	1470		1675	1785	1915	2115	2325
	k	1270	1380	1490	1590	1700	1820	2020	2230
	Holes	32	32	32	36	36	40	44	55
	d_2	37	41	44	44	44	50	50	48
	b	43	45	45	55	60	60	65	49/50
PN 16	D		1485		1685	1820	1930	2130	950
	k		1390		1590	1710	1820	2020	2325
	Holes		32		36	36	40	44	2230
	d_2		50		50	57	57	57	75
	b		57		64	67	70	70	48
PN 25	D		1530		1755	1865	1975	2195	62
	k		1420		1640	1759	1860	2070	
	Holes		32		36	52	40	44	
	d_2		57		62	48	62	70	
	b		74		76	77.5	84	90	
PN 40	D		1575		1795		2025		
	k		1460		1680		1900		
	Holes		32		36		40		
	d_2		62		62		70		
	b		80		85		108		

Flange for the actuator connection between gear unit and valve in acc. with DIN EN ISO 5211.

* PN 6: Dimensions as PN 10, drilling template PN on request

We reserve the right to make technical changes and use similar or higher-quality materials. Drawings are non-binding



Dimensions / weights

Dimensions in mm. Net weights for version with handwheel														
DN	150	200	250	300	350	400	450	500	600	700	800	900	1000	
PN 6 d:												500	400	500
e ₁												509	806	828
e ₂												772	885	940
e ₃												684	736	802
e ₄												125	125	125
e ₅												173	173	173
e ₆												150	150	150
e ₇												609	661	727
h ₂												395	432	432
h ₃												515	565	630
l ₂												450	550	600
Gear unit												GS 125.3	GS 125.3	GS 125.3
Type												VZ 4	VZ 4	VZ 4
Turns/stroke												51	51	51
Net weight kg												600	740	920
PN 10 d:		250	250	250	250	350	400	400	500	500	400	400	400	400
e ₁		150	180	215	240	261	306	345	392	462	512	576	642	642
e ₂		308	351	401	411	465	508	539	625	722	772	830	900	900
e ₃		256	299	349	359	403	442	473	541	634	684	750	820	820
e ₄		50	50	50	50	63	80	80	100	125	125	160	160	160
e ₅		73	73	73	73	94	111	111	148	173	173	218	218	218
e ₆		54	54	54	54	75	88	88	105	150	150	165	175	175
e ₇		216	259	309	319	358	385	416	466	559	609	675	729	729
h ₂		231	231	231	231	231	308	308	407	395	432	520	520	520
h ₃		175	205	232	265	288	312	340	395	455	515	565	630	630
l ₂		185	225	260	270	300	250	300	330	400	450	550	600	600
Gear unit												GS 125.3	GS 125.3	GS 160.3
Type					GS 50.3	GS 63.3	GS 80.3	GS 100.3	GS 100.3	GS 125.3	GS 125.3	GS 160.3	GS 160.3	GS 200.3
Turns/stroke					12.75	12.75	13.25	13	13	51	51	110.5	110.5	110.5
Net weight kg		44	60	81	110	130	190	240	320	470	620	800	800	1050
PN 16 d:	250	250	250	250	350	400	400	500	500	500	400	500	500	500
e ₁	115	150	180	215	240	275	306	357	413	470	537	615	666	666
e ₂	279	308	351	401	440	463	508	583	673	736	822	935	985	985
e ₃	225	256	299	349	378	401	460	499	585	648	721	839	888	888
e ₄	50	50	50	50	63	80	100	100	125	125	160	200	200	200
e ₅	73	73	73	73	94	94	148	148	173	173	218	273	273	273
e ₆	54	54	54	54	75	75	105	105	150	150	175	208	208	208
e ₇	185	216	259	309	333	356	385	424	510	573	631	724	773	773
h ₂	231	231	231	231	283	308	367	407	395	395	517	642	642	642
h ₃	150	175	205	232	265	295	325	362	425	460	520	570	635	635
l ₂	150	185	225	260	270	320	250	300	330	400	450	550	600	600
Gear unit										GS 125.3	GS 125.3	GS 160.3	GS 160.3	GS 200.3
Type					GS 50.3	GS 63.3	GS 80.3	GS 100.3	GS 100.3	VZ 4	VZ 4	GZ 8:1	GZ 8:1	GZ 16:1
Turns/stroke					12.75	12.75	13.25	13	13	51	51	110.5	110.5	216
Net weight kg	30	44	60	85	116	155	237	300	460	670	775	970	970	1320
PN 25 d:	250	250	250	350	400	400	400	400	500	400	500	500	500	500
e ₁	115	150	180	215	240	275	312	377	425	490	571	612	681	681
e ₂	277	308	351	419	450	485	555	636	679	755	894	954	1051	1051
e ₃	225	256	299	357	384	419	467	548	591	675	797	839	911	911
e ₄	50	50	50	63	80	80	100	125	125	160	200	200	250	250
e ₅	73	73	73	94	111	111	148	173	173	218	273	273	335	335
e ₆	54	54	54	75	88	88	105	150	150	175	208	208	258	258
e ₇	185	216	259	312	327	362	392	473	516	578	682	724	781	781
h ₂	231	231	231	283	308	308	428	432	452	535	642	667	722	722
h ₃	155	185	218	248	285	315	340	370	428	485	550	600	665	665
l ₂	160	200	240	255	285	320	250	300	330	400	450	550	600	600
Gear unit										GS 125.3	GS 125.3	GS 125.3	GS 160.3	GS 200.3
Type					GS 50.3	GS 63.3	GS 80.3	GS 100.3	GS 100.3	VZ 4	VZ 4	VZ 4	GZ 8	GS 200.3
Turns/stroke					12.75	12.75	13.25	13	13	51	51	51	108.5	216
Net weight kg	32	50	67	103	133	174	280	380	490	800	800	1250	1685	1685
PN 40 d:	250	250	250	350	400	400	400	400	500	400	500	500	500	500
e ₁	133	168	198	235	260	307	307	371	417	487	571	613	681	681
e ₂	289	320	363	425	440	555	555	641	715	770	894	954	1051	1051
e ₃	227	258	301	359	384	467	467	553	614	675	797	839	894	894
e ₄	63	63	63	80	80	125	125	125	160	200	200	200	250	250
e ₅	94	94	94	111	111	173	173	173	218	305	305	305	~385	~385
e ₆	75	75	75	88	88	125	125	150	165	208	208	208	2558	2558
e ₇	185	216	259	312	327	392	392	478	524	585	682	724	781	781
h ₂	263	263	263	288	308	332	432	432	537	~600	~670	~670	~725	~725
h ₃	155	195	230	260	295	345	350	395	460	505	580	640	700	700
l ₂	160	200	240	260	285	360	300	390	460	400	450	550	600	600
Gear unit										GS 125.3	GS 125.3	GS 125.3	GS 160.3	GS 200.3
Type	GS 63.3	GS 63.3	GS 63.3	GS 80.3	GS 80.3	GS 80.3	VZ 4	VZ 4	VZ 4	GZ 8:1	GZ 16.1	GZ 16.1	GZ 16.1	GZ 16
Turns/stroke	12.75	12.75	12.75	13.25	13.25	51	51	51	110.5	216	216	216	216	212

* PN 6: Dimensions as PN 10, drilling template PN on request

We reserve the right to make technical changes and use similar or higher-quality materials. Drawings are non-binding



Dimensions / weights

Dimensions in mm. Net weights for version with handwheel								
DN	1100	1200	1300	1400	1500	1600	1800	2000
PN 6* d ₁		500		400	400	400	400	400
e ₁		738		855	920	970	1100	1240
e ₂		1014		1220	1290	1380	1490	1705
e ₃		919		1100	1155	1245	1355	1545
e ₄		160		200	250	250	250	315
e ₅		218		315	365	365	365	555
e ₆		175		215	268	268	268	340
e ₇		829		907	982	1013	1124	1332
h ₂		537		665	745	745	745	865
h ₃		740		845	870	965	1065	1180
l ₂		700		800	850	900	1000	1100
Gear unit		GS 160.3		GS 200.3		GS 250.3		GS 315.2
Type		GZ 8:1		GZ 16		GZ 16:1		
Turns/stroke		110.5		106		208		424
Net weight kg		1555		2060	2525	3685	4625	7500
PN 10 d ₁	400	500	400	400	500	500	500	500
e ₁	692	763	830	880	970	995	1140	1270
e ₂	968	1104	1235	1285	1290	1386	1460	1825
e ₃	873	989	1100	1150	1130	1226	1300	1630
e ₄	160	200	250	250	250	250	315	400
e ₅	218	273	365	365	365	365	555	610
e ₆	175	208	268	268	268	268	340	430
e ₇	783	874	880	920	985	1013	1154	1370
h ₂	517	667	745	745	745	745	865	963
h ₃	680	740	795	845	900	965	1065	1180
l ₂	650	700	750	800	850	900	1000	1100
Gear unit	GS 160.3	GS 200.3		GS 200.3			GS 315.2	GS 400.2
Type	GZ 8:1	GZ 16		GZ 16:1			GZ 35 32:1	GZ 35 32:1
Turns/stroke	110.5	216		208			424	432
Net weight kg	1390	1740	2260	2545	3525	3985	4850	7800
PN 16 d ₁		500		400	400	400	630	500
e ₁		784		915	1000	1045	1170	1301
e ₂		1154		1235	1315	1415	1725	1684
e ₃		1014		1075	1155	1255	1530	1489
e ₄		250		315	315	315	400	400
e ₅		335		555	555	555	610	610
e ₆		258		340	340	340	430	830
e ₇		884		928	1010	1058	1270	1314
h ₂		722		865	865	865	963	992
h ₃		750		850	920	970	1070	1200
l ₂		700		800	850	900	1000	1100
Gear unit		GS 250.3		GS 250.3			GS 400.2	GS 400.2
Type		GZ 16		GZ 32:1			GZ 35 32:1	GZ 35 32:1
Turns/stroke		212		424			432	432
Net weight kg		2090		2945	3755	4450		8300
PN 25 d ₁		500						
e ₁		813					1194	
e ₂		1175					1618	
e ₃		1035					1425	
e ₄		250					40	
e ₅		335					610	
e ₆		258					430	
e ₇		895					1250	
h ₂		722						
h ₃		780					1110	
l ₂		700					670	
Gear unit		GS 200.3					GS 400.2	
Type		GZ 16:1					GZ 35	
Turns/stroke		216						
Net weight kg		2400						
PN 40 d ₁		500		500				
e ₁		813		1025				
e ₂		1269		1483				
e ₃		1108		1288				
e ₄		315		400				
e ₅		490		610				
e ₆		340		430				
e ₇		895		1030				
h ₂		~865		~965				
h ₃		800		925				
l ₂		900		1000				
Gear unit		GS 315		GS 400				
Type		GZ 30		GZ 35				
Turns/stroke		424		432				

* PN 6: Dimensions as PN 10, drilling template PN on request

We reserve the right to make technical changes and use similar or higher-quality materials. Drawings are non-binding



Operating limits VAG EKN Abbsperrklappe

The streamline in the butterfly valve creates hydraulic forces on the valve disc. In this respect VAG Butterfly Valves are designed for maximum velocities acc. to the standard EN 593 table 2. Higher velocities are creating higher hydraulic forces towards the disc. therefore the differential pressure at the valve acc. to our "limiting curves for EKN Butterfly Valves" has to be considered.

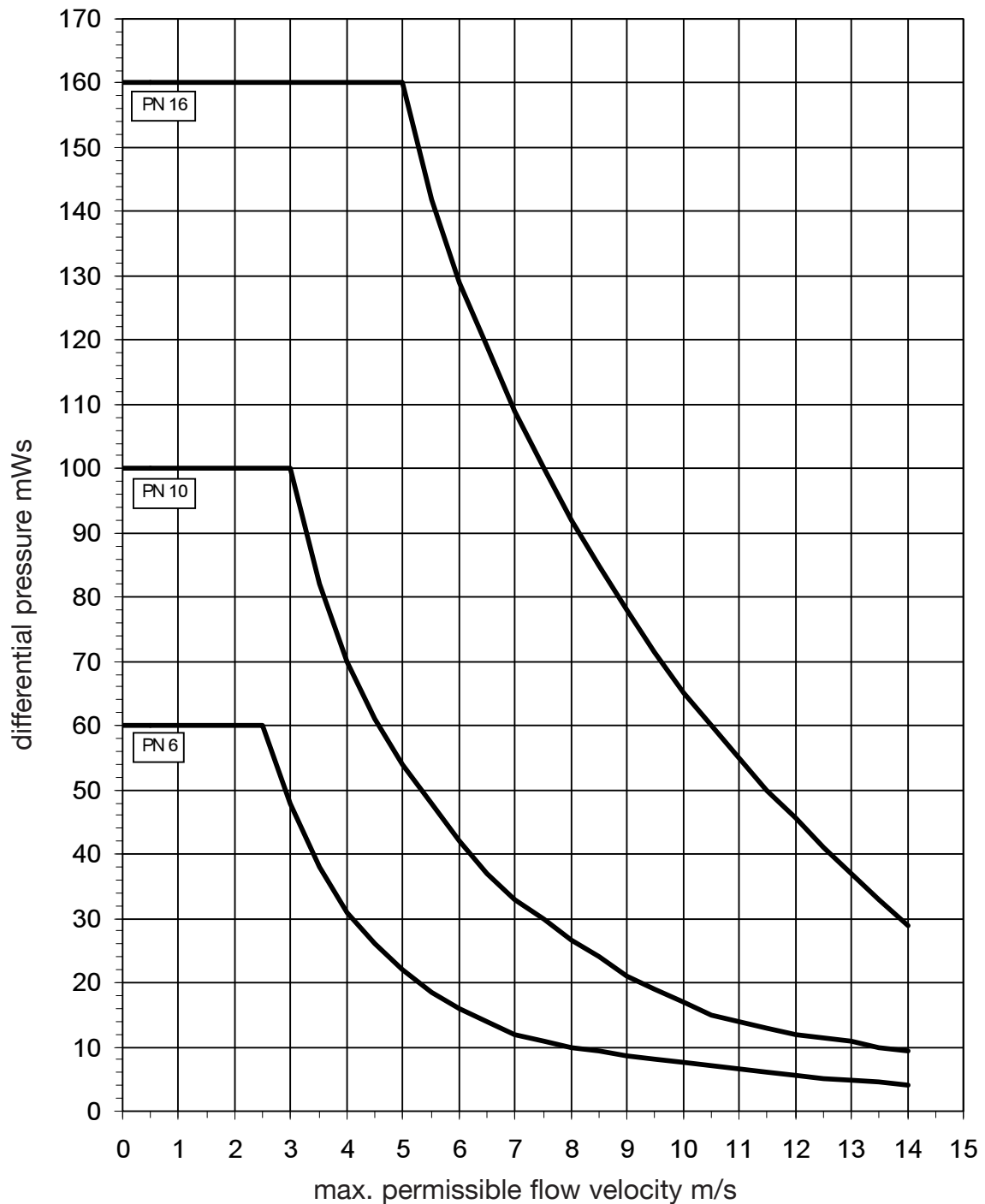

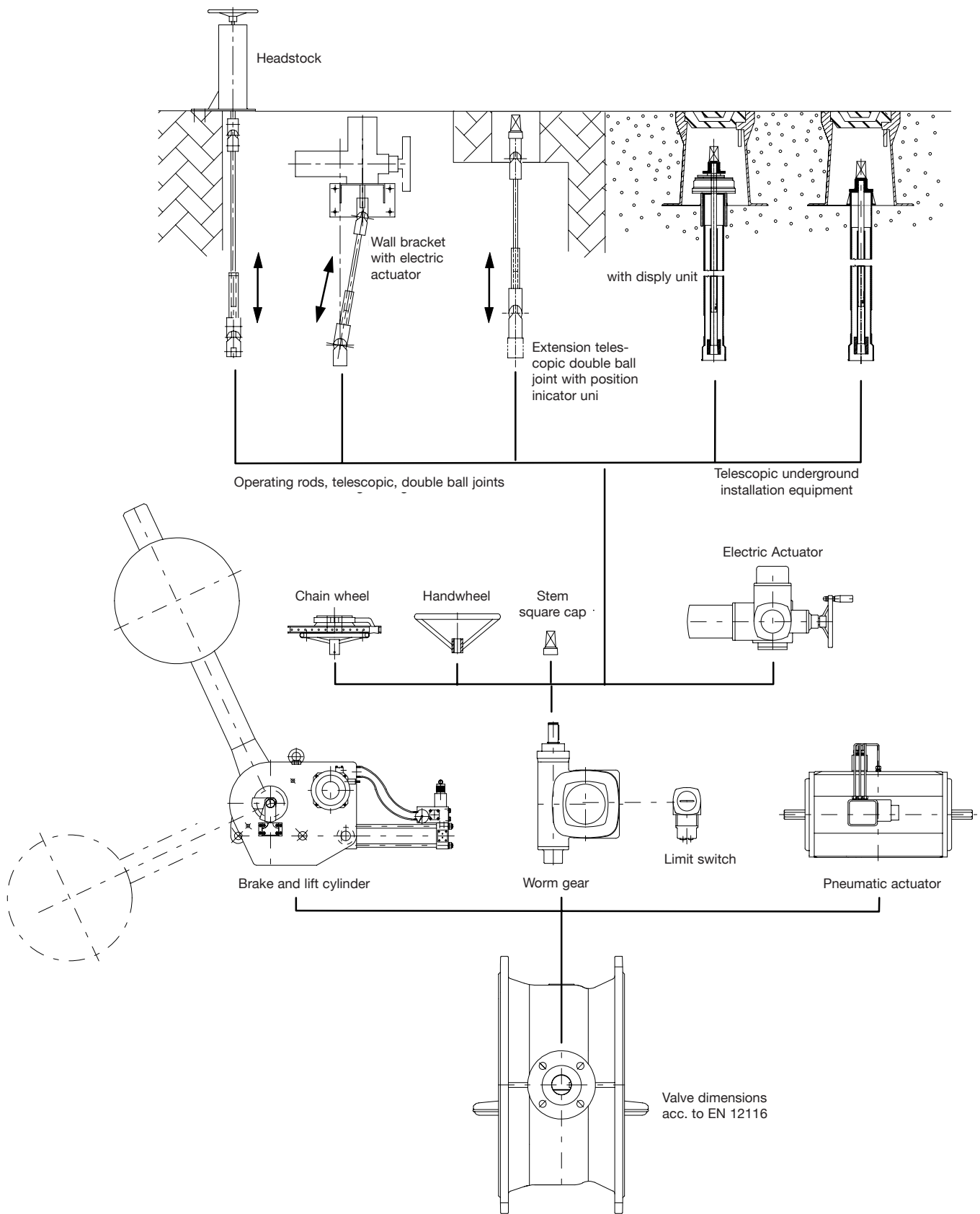

EKN Butterfly Valve