

FC&C

Creates your solutions



IM SR QUICK RELIEF VALVE

The IM-SR avoid water hammer and protects pumps and pipelines from pump start-up and shut off pressure surges due to power failure.

Standard Pilot regulation range: 1,0 – 10 bar
Optional: 1,5 – 22 bar

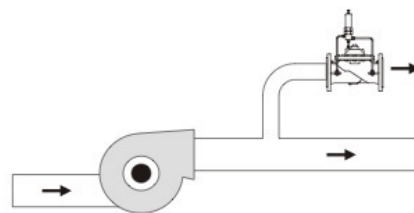

Typical installation example

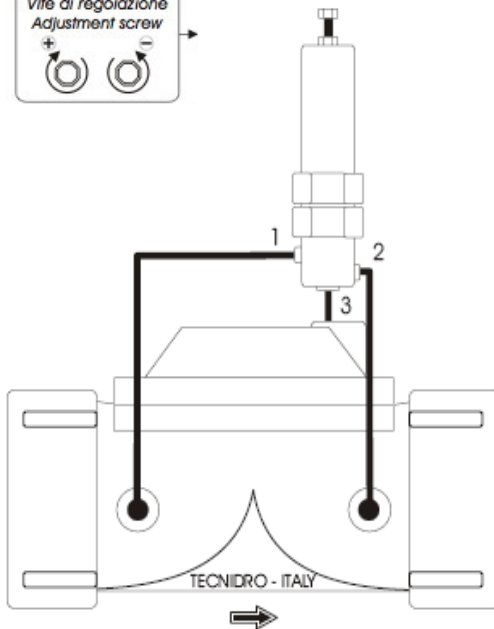
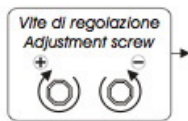

Ø	L	H	B	P
Mod.	(mm)	(mm)	(mm)	(Kg)
DN 50	175	165	165	7.5
DN 65	175	165	165	7.5
DN 80	280	200	210	18.5
DN 80P	220	200	200	11.0
DN 80E	220	120	200	12.0
DN 100	300	220	220	20.5
DN100P	220	220	220	13.0
DN100E	245	135	220	14.0
DN 125	325	250	250	24.5
DN 150	350	320	320	46.0
DN 200	400	340	340	50.0
DN 250	450	470	405	90.0
DN 300	500	500	460	135.0
DN 350	550	520	520	155.0
DN 400	600	580	580	170.0
DN 500	700	680	680	195.0

Flangiato
Flanged
Bridado
Brides

ISO PN16/10
ANSI 150
BS Table D

